

**GCheat<sup>®</sup>**

The highest degree.



GC-cart Hochleistungsheizpatronen  
*GC-cart High-density cartridge heaters*



GC-cart

## GC-cart

### Hochleistungsheizpatronen High-density cartridge heaters

GC-cart Hochleistungsheizpatronen garantieren durch ein spezielles Herstellungsverfahren und durch den Einsatz hochwertiger Materialien eine hohe Standfestigkeit auch unter schwierigen Betriebsbedingungen. Hohe Oberflächenbelastungen ermöglichen eine entsprechend große Leistung auf kleinem Einbauraum, bei Betriebstemperaturen von bis zu 750 °C am Heizpatronenmantel. GC-cart Hochleistungsheizpatronen entsprechen in metrischen und Zollmaßen internationalen Normen. Wir gehen auf individuelle Kundenwünsche ein und fertigen auf Anfrage Durchmesser zwischen 6 mm und 45 mm. Für besondere Einsatzfälle bietet GC-heat die Entwicklung und Fertigung von kundenspezifischen Ausführungen, zum Beispiel mit individueller Leistungsverteilung, schaltbaren Heizzonen, integriertem Thermoelement sowie Ein- und Ausbauhilfen. Unterschiedliche Zuleitungsarten ermöglichen darüber hinaus die Anpassung der GC-heat Hochleistungsheizpatronen an die jeweilige Einbausituation.

*Due to a special manufacturing process and the use of high-quality materials, GC-cart high-density cartridge heaters guarantee a high level of stability even under difficult operating conditions. High surface loads enable equally high performance in a compact space, even at operating temperatures of up to 750 °C on the cartridge heater's sheath. GC-cart high-density cartridge heaters conform to metric and imperial international norms. We cater to individual customer requirements and produce diameters between 6 mm and 45 mm on request. GC-heat is also able to design and produce bespoke versions for special applications, e.g. with individual power distribution, switchable heating zones and integrated thermocouples, as well as mounting and dismantling aids. Various leads enable the GC-heat high-density cartridge heaters to be adapted to suit the particular application.*

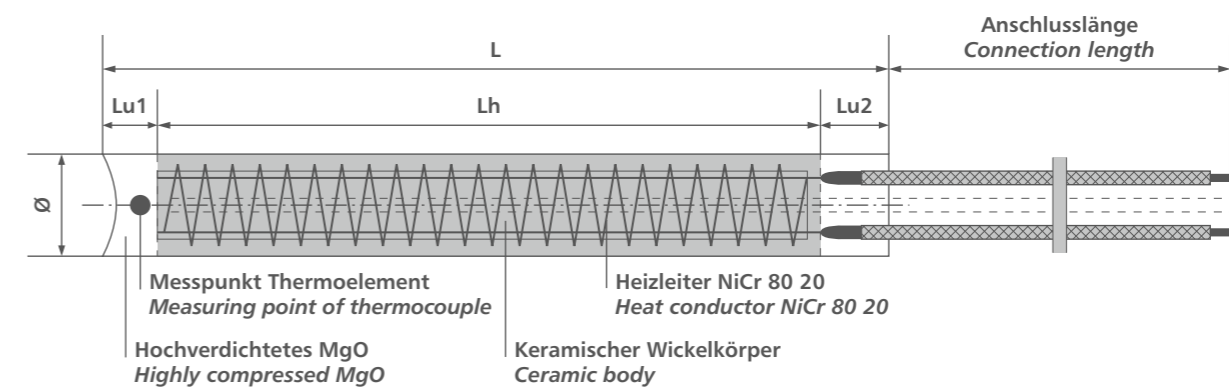

#### Technische Möglichkeiten und Varianten Technical possibilities and options

- Hohe Leistung auf kleinem Einbauraum  
High performance in compact spaces
- Individuelle Leistungsverteilung  
Individual power distribution
- Schaltbare Zonen  
Switchable zones
- Integriertes Thermoelement  
Integrated thermocouple
- Unterschiedliche Zuleitungsarten und Anschlusstypen  
Various leads and connections
- Stückprüfung nach VDE0721  
Individual quality inspection according to VDE0721
-  Auch als explosionsgeschützte Ausführung erhältlich (siehe Seite 48)  
Also available as explosion-proof version (see page 48)

#### Einsatzbereiche Applications

- Kunststoffindustrie  
Plastic industry
- Heißkanaltechnik  
Hot runner systems
- Verpackungsanlagen  
Packaging machines
- Medizinische Geräte  
Medical equipment
- Gießereitechnik  
Foundry technology
- Zahlreiche weitere thermische Bearbeitungsprozesse  
Numerous other thermal processes

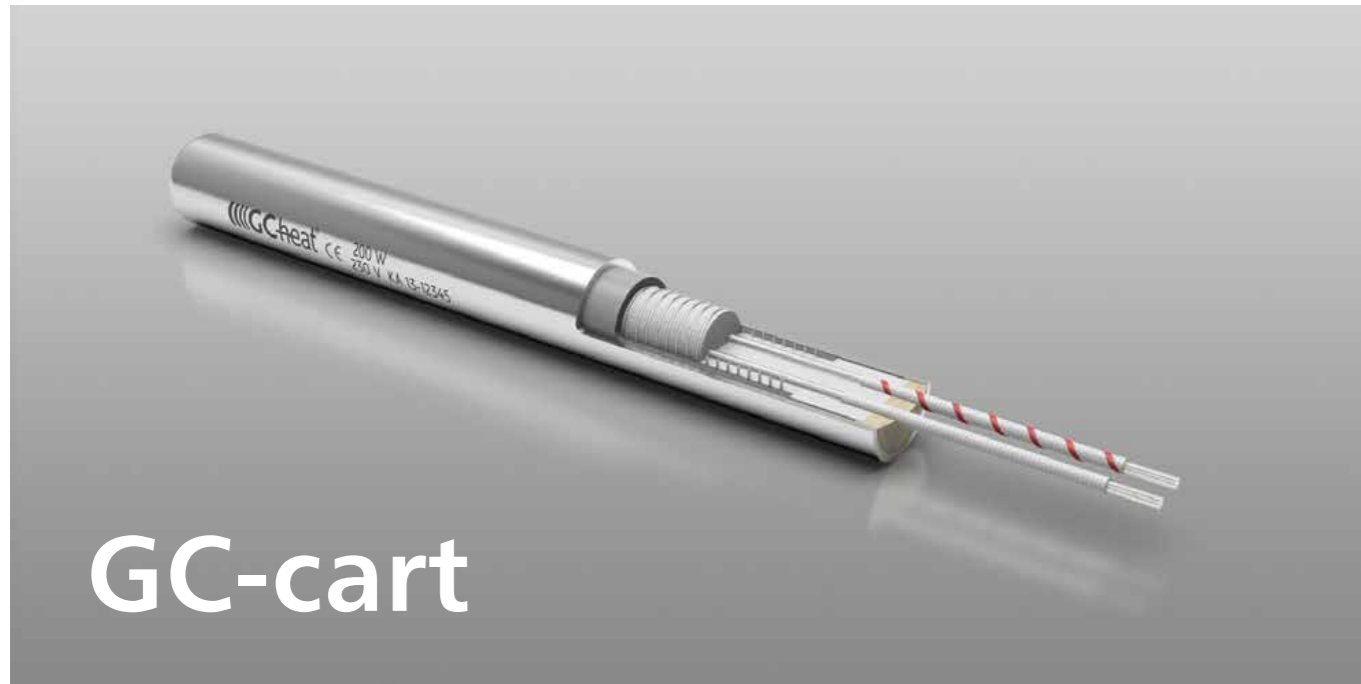

GC-cart

## GC-cart

### Standardausführung Standard version

#### Anschlussverguss Connection encapsulation

- Keramikkitt, Silikonverguss, Epoxidharz, PTFE-Scheibe  
Ceramic filler, silicone encapsulation, epoxy resin, PTFE disc

#### Allgemeine Merkmale General characteristics

- Anschluss: standardmäßig glasseidenisolierte Litze, 1000 mm  
Weitere Varianten: siehe Seite 38  
Connection: 1000 mm standard glass-fibre-insulated lead  
For other versions, see page 38

- Isolationswiderstand: > 5 MΩ  
Insulation resistance: >5 MΩ
- Mantel-/Betriebstemperatur: max. 750 °C  
Sheath/operating temperature: max. 750 °C
- Qualitätskontrolle: nach VDE0721  
Quality assurance: according to VDE0721
- Sonderlösungen: Auf Anfrage fertigen wir auch abweichende Abmessungen  
Special solutions: different sizes can be made on request

- ∅ Durchmesser GC-cart  
Diameter GC-cart
- L Gesamtlänge  
Total length
- Lh Beheizte Länge  
Heated length
- Lu1 Unbeheizte Zone Boden  
Unheated zone, bottom
- Lu2 Unbeheizte Zone Kopf  
Unheated zone, head

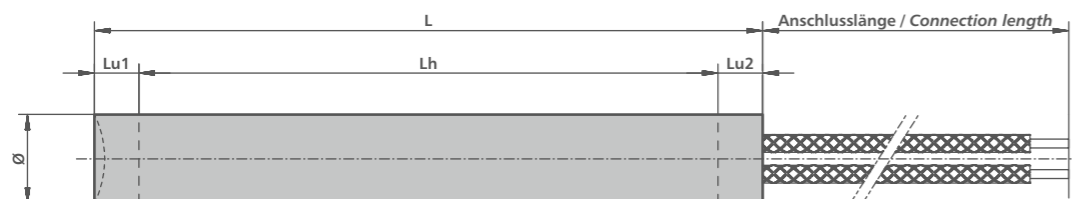

GC-cart Hochleistungsheizpatrone GC-cart high-density cartridge heater	6.0 – 6.2	6.3 – 7.5	7.8 – 9.0	9.3 – 11.5	11.9 – 12.5
Anschlussspannung Connection voltage	max. 415 V		max. 500 V		
Max. Oberflächenbelastung Max. surface load	50 W/cm <sup>2</sup>				
Durchmessertoleranz Diameter tolerance	-0.02 mm / -0.06 mm				
Längentoleranz Length tolerance	± 1.5%, min. ± 1 mm				
Leistungstoleranz Wattage tolerance	± 10%				
Unbeheizt am Boden* (Lu1) Unheated at the bottom (Lu1)	min. 6 mm				
Unbeheizt am Kopf* (Lu2) Unheated at the head (Lu2)	min. 6 mm		min. 7 mm		
Thermoelement Typ K / Typ J Thermocouple type K / type J	□ Lage frei wählbar Freely selectable position				
Widerstandsthermoelement PT 100 Resistance thermocouple PT 100	-		□		
Hochspannungsfestigkeit High-voltage stability	1000 V		1250 V		1500 V
Mantelmaterial Sheath material	CrNi-Stahl CrNi steel				
Leistungsverteilung Wattage distribution	□				
Zonen einzeln schaltbar Zones individually switchable	-		□ max. mit 4 Litzen with max. 4 leads		

GC-cart Hochleistungsheizpatrone GC-cart high-density cartridge heater	12.6 – 17.0	17.8 – 20.4	22.0	24.7 – 26.0	29.0 – 32.5
Anschlussspannung Connection voltage	max. 500 V				
Max. Oberflächenbelastung Max. surface load	50 W/cm <sup>2</sup>				
Durchmessertoleranz Diameter tolerance	-0.02 mm / -0.06 mm				
Längentoleranz Length tolerance	± 1.5%, min. ± 1 mm				
Leistungstoleranz Wattage tolerance	± 10%				
Unbeheizt am Boden* (Lu1) Unheated at the bottom (Lu1)	min. 11 mm		min. 12 mm		min. 13 mm
Unbeheizt am Kopf* (Lu2) Unheated at the head (Lu2)	min. 10 mm			min. 12 mm	
Unheated at the head (Lu2)			min. 19 mm		
Thermoelement Typ K / Typ J Thermocouple type K / type J	□ Lage frei wählbar Freely selectable position				
Widerstandsthermoelement PT 100 Resistance thermocouple PT 100	□				
Hochspannungsfestigkeit High-voltage stability	1500 V				
Mantelmaterial Sheath material	CrNi-Stahl CrNi steel				
Leistungsverteilung Wattage distribution	□				
Zonen einzeln schaltbar Zones individually switchable	□ max. mit 4 Litzen with max. 4 leads			□ max. mit 6 Litzen with max. 6 leads	

Technische Änderungen und Irrtümer vorbehalten. Technical changes and errors excepted.

■ Standardausführung Standard version

□ Optionale Ausführung Optional version

— Nicht verfügbar Not available

Weitere Ausführungen auf Anfrage. Other designs available on request.



GC-cart

## GC-cart

### Anschlusstypen Connection types

#### Litzen, einreduziert Continuous leads

**G** Glasseidenisierte Litze, silikongetränkt,  
max. 350 °C  
Glass silk insulated leads, max. 350 °C

**SFG** Glasseidenisierte Litze, verstärkte Ausführung,  
max. 450 °C  
Glass silk insulated leads, strengthened version  
max. 450 °C

**T** PTFE-isolierte Litze, max. 260 °C  
PTFE leads, max. 260 °C

**SLV** Silikonlitze, max. 180 °C  
Silicone leads, max. 180 °C

**SLF** Flexible Silikonlitze, max. 180 °C  
Highly flexible silicone leads, max. 180 °C

**M** Glasseidenisierte Litze, hochtemperatur-  
beständig, max. 600 °C  
High-temperature glass silk insulated leads,  
max. 600 °C

#### Beperte, blanke Litze Beaded leads

**P** Beperte Nickellitze, max. 750 °C  
Ceramic beads, max. 750 °C

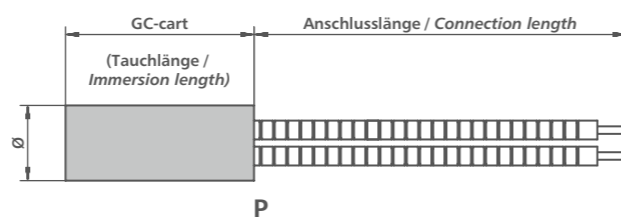
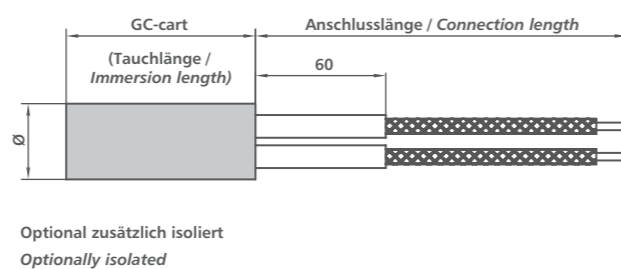
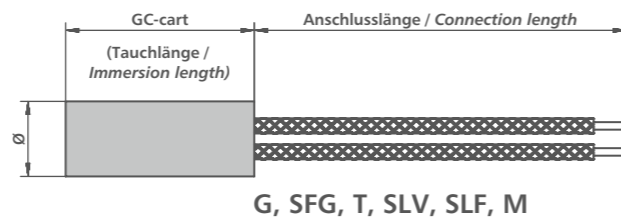

Silikonkabel, max. 180 °C  
Silicone cable, max. 180 °C

**SIK** 2-, 3-, 5-adriges Silikonkabel mit Rohrstück  
2-, 3- or 5-wired silicone cable with tube

Ø GC-cart		Ø R x R
6.5	1/4"	7.5 x 40
8.0		9.0 x 40
10.0		11.0 x 40
12.0		14.0 x 40
12.5	1/2"	14.0 x 40
16.0	5/8"	14.0 x 40
20.0	3/4"	18.0 x 40

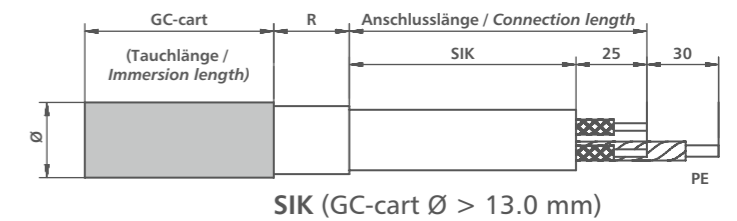
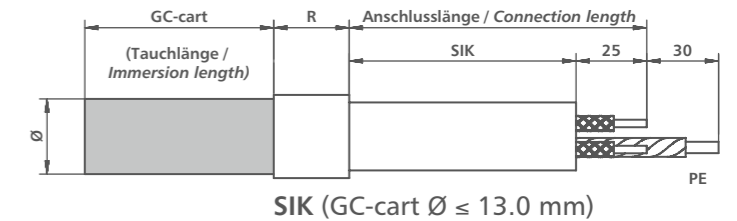

Glasseidenschlauch, max. 250 °C  
Glass silk insulated sleeve, max. 250 °C

**GHI** Einreduzierte Litze mit Glasseidenschlauch  
Continuous leads with glass silk insulated sleeve

Ø GC-cart		max. AD GH
8.0		6.0
10.0	3/8"	9.0
12.0		10.0
12.5	1/2"	10.0
16.0	5/8"	13.0
	3/4"	16.0
20.0		17.0

AD = outer diameter

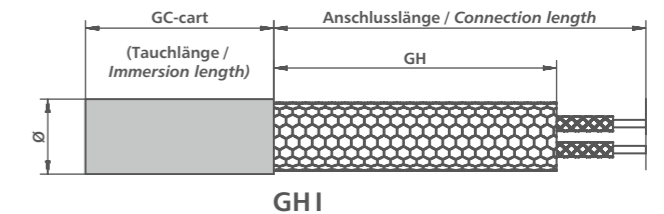

**GH** Glasseidenschlauch mit Verbindungsrohr  
Continuous leads with glass silk insulated sleeve  
and tube

Ø GC-cart		Ø R x R	max. AD GH
6.5	1/4"	7.5 x 40	6.0
8.0		9.0 x 40	7.0
10.0	3/8"	11.0 x 40	9.0
12.0		14.0 x 40	11.0
12.5	1/2"	14.0 x 40	11.0
16.0	5/8"	14.0 x 40	11.0
	3/4"	18.0 x 40	17.0
20.0		18.0 x 40	17.0

AD = outer diameter

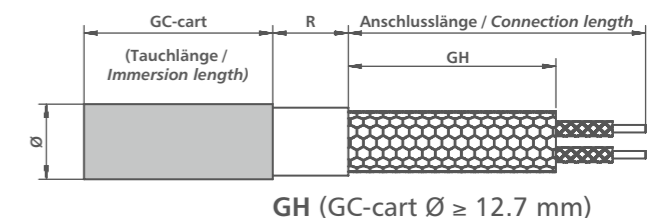
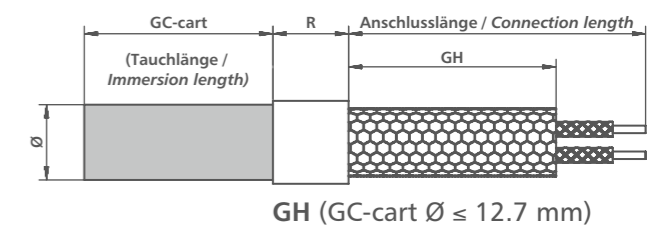

Weitere Ausführungen auf Anfrage. Other designs available on request.

**Metallwellschlauch, max. 220 °C  
Metal sleeve, max. 220 °C**

**MWS I** Einreduzierte Litze mit Metallwellschlauch von innen  
*Continuous lead with metal sleeve from the inside*

Ø GC-cart	Ø MWS AD
12.0	11.0
12.5 1/2"	11.0
16.0 5/8"	14.0
3/4"	14.0
20.0	17.0

AD = outer diameter

**MWS** Einreduzierte Litze mit Metallwellschlauch mit Verbindungsrohr  
*Continuous lead with metal sleeve with tube*

Ø GC-cart	Ø R x R	Ø MWS AD
6.5 1/4"	7.5 x 40	7.0
8.0	9.0 x 40	8.0
10.0 3/8"	11.0 x 40	10.0
12.0	14.0 x 40	13.0
12.5 1/2"	14.0 x 40	13.0
16.0 5/8"	14.0 x 40	13.0
20.0 3/4"	18.0 x 40	16.0

AD = outer diameter

**Metallgeflechtschlauch, max. 250 °C  
Braided metal sleeve, max. 250 °C**

**MGSI** Metallgeflechtschlauch ohne Verbindungsrohr  
*Braided metal sleeve without tube*

Ø GC-cart	Ø R10	Ø MGS
6.5 1/4"	9.0	4.0-6.0
8.0	11.0	4.0-6.0
10.0 3/8"	14.0	5.0-12.0
12.0	16.0	5.0-12.0
12.5 1/2"	16.0	5.0-12.0
16.0 5/8"		5.0-12.0
3/4"		12.0-22.0
20.0		12.0-22.0
25.0		12.0-22.0

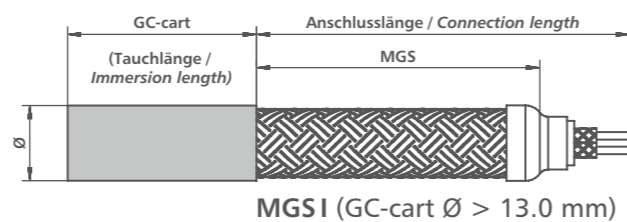
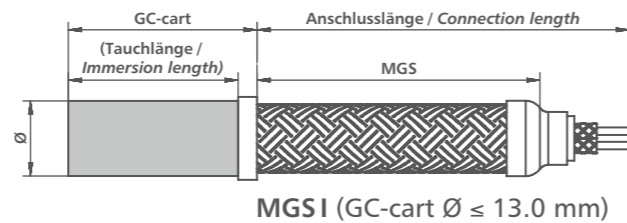
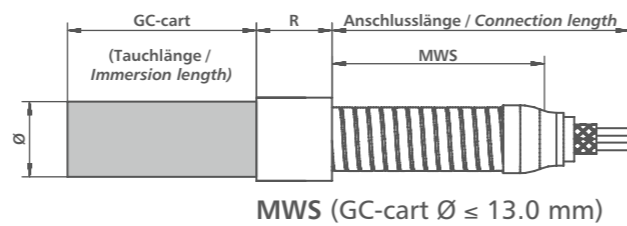
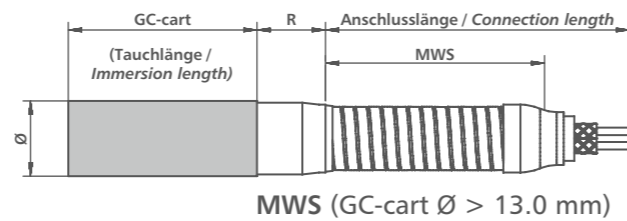
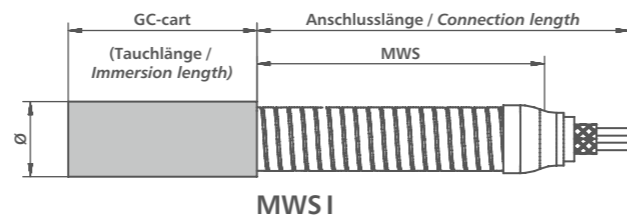

Weitere Ausführungen auf Anfrage. *Other designs available on request.*

**Metallgeflechtschlauch, max. 250 °C  
Braided metal sleeve, max. 250 °C**

**MGS** Metallgeflechtschlauch mit Verbindungsrohr  
*Braided metal sleeve with tube*

Ø GC-cart	Ø R x R	Ø R10
6.5 1/4"	7.5 x 40	10.0
8.0	9.0 x 40	11.0
10.0 3/8"	11.5 x 40	14.0
12.0	14.0 x 40	
12.5 1/2"	14.0 x 40	
16.0 5/8"	14.0 x 40	
20.0 3/4"	18.0 x 40	
25.0	22.0 x 40	

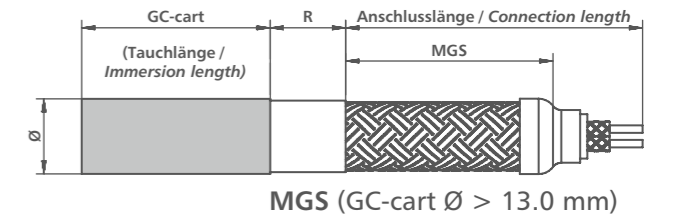
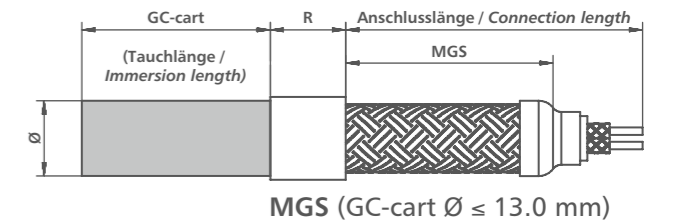
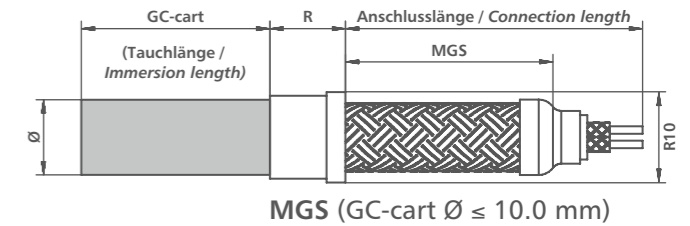

**Edelstahlwellschlauch, max. 450 °C  
Stainless-steel sleeve, max. 450 °C**

**RWEI** Edelstahlwellschlauch von innen  
*Stainless-steel sleeve from the inside*

**RWE** Edelstahlwellschlauch mit Verbindungsrohr  
*Stainless-steel sleeve with tube*

Ø GC-cart	Ø R x R	Ø RWE
8.0	9.0 x 40	9.7
10.0 3/8"	11.0 x 40	9.7
12.0	14.0 x 40	12.7
12.5 1/2"	14.0 x 40	12.7
16.0 5/8"	14.0 x 40	12.7
20.0 3/4"	18.0 x 40	16.8

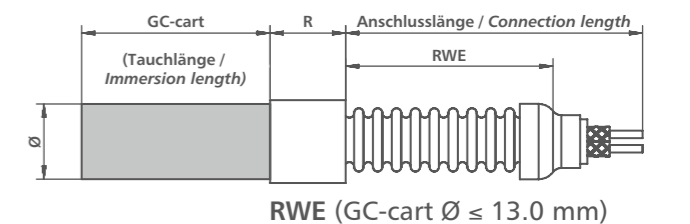
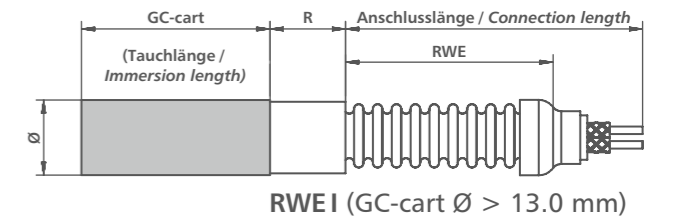

Weitere Ausführungen auf Anfrage. *Other designs available on request.*

SIS Silikonschlauch mit Verbindungsrohr  
Silicone sleeve with connection tube

Ø GC-cart	Variante Type	R1 x R	Ø SIS x Wanddicke Wall thickness	Ø R2
6.0-6.5	außen verpresst outside pressure-grouted	7.5 x 40	9.4 x 1.2	10.5
8.0	außen verpresst outside pressure-grouted	9.0 x 40	11.4 x 1.2	12.5
9.33-10.0	innen verpresst inside pressure-grouted	11.0 x 40	9.4 x 1.2	-
12.0-12.5	innen verpresst inside pressure-grouted	14.0 x 40	11.4 x 1.2	-
15.88-16.0	innen verpresst inside pressure-grouted	14.0 x 40	11.4 x 1.2	-

SIS I Silikonschlauch innen verpresst  
Silicon sleeve pressed inside

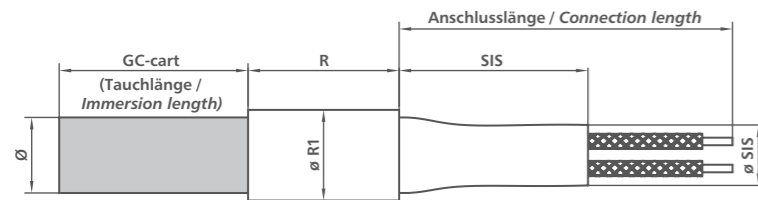

SIS A Silikonschlauch außen verpresst  
Silicon sleeve pressed outside

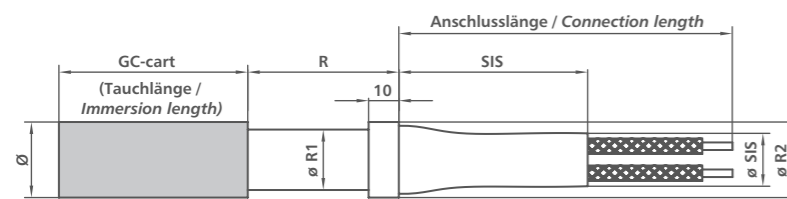

Drehteil  
Turned part

DR Rechtwinkliges Drehteil mit Verbindungsrohr  
Right-angle turned part with tube

Ø GC-cart	a	b	Ø R x R
8.0	7.8	10.0	8.0 x 40
10.0	3/8"	9.0	9.0 x 40
12.0		12.0	10.0 x 40
12.5	1/2"	12.0	10.0 x 40
16.0	5/8"	15.5	14.0 x 40
	3/4"	19.0	18.0 x 40
20.0		19.0	18.0 x 40

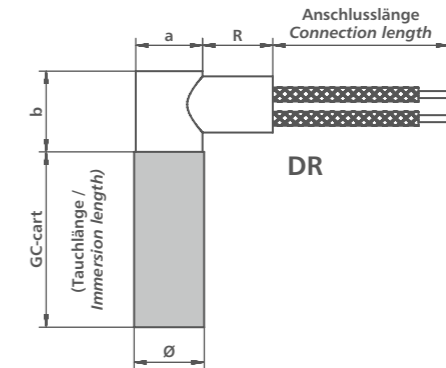

Winkelklotz  
Angular block

WR Winkelklotz mit Verbindungsrohr  
Angular block with tube

Ø GC-cart	a	Ø R x R
6.5	1/4"	9.0 x 40
8.0		9.0 x 40
10.0	3/8"	11.0 x 40
12.0		11.0 x 40
12.5	1/2"	11.0 x 40
16.0	5/8"	14.0 x 40
20.0	3/4"	18.0 x 40
25.0		24.0 x 40
30.0		28.0 x 40

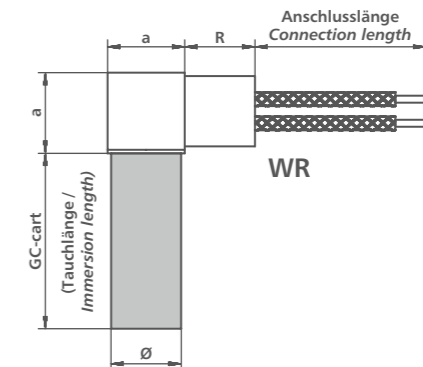

Lasche  
Lug

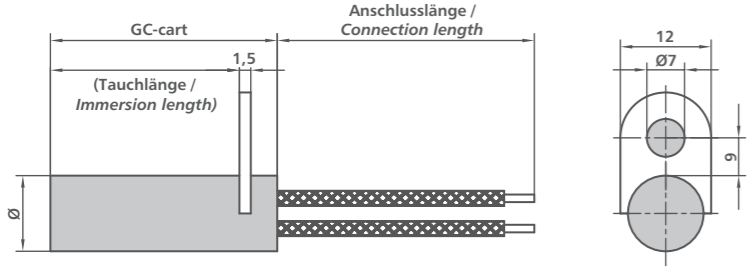

Variante 1: Ø GC-cart < 12  
Type 1: Ø GC-cart < 12

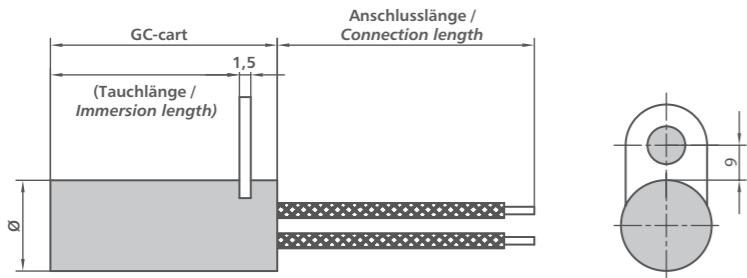

Variante 2: 25 > Ø GC-cart ≥ 12  
Type 2: 25 > Ø GC-cart ≥ 12

Flansch  
Flange

F1 Flansch, Variante 1  
Flange, type 1

Ø GC-cart	Ø F	Ø L	Ø B	t
6.5	1/4"	18.0	13.0	2.2
8.0		18.0	13.0	2.2
10.0	3/8"	27.0	20.0	3.2
12.0		27.0	20.0	3.2
12.5	1/2"	27.0	20.0	3.2
16.0	5/8"	33.0	25.6	3.2
20.0	3/4"	33.0	25.6	3.2
20.0		33.0	27.4	3.5

F2 Flansch, Variante 2  
Flange, type 2

Ø GC-cart	Ø F	Ø L	Ø B	t
≤ 15.0	35.0	25.0	4.2	2.0
≤ 25.0	44.0	34.0	4.2	2.0
≤ 32.0	52.0	42.0	4.2	2.0
≤ 40.0	62.0	52.0	4.2	2.0

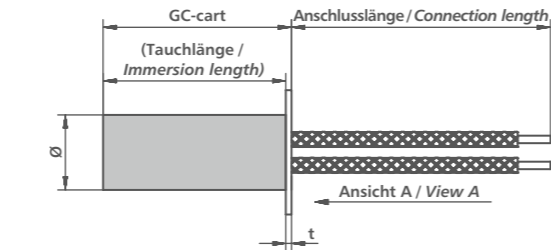

F

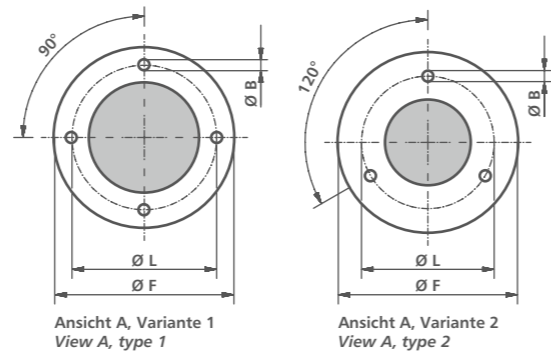

Anschlussgehäuse  
Connection housing

BAO Anschlussgehäuse  
Connection housing

Ø GC-cart	Ø K	H	N
12.7	31.5	67.0	M16x1.5
16.0	31.5	67.0	M16x1.5
20.0	36.5	67.0	M20x1.5
25.0	36.5	67.0	M20x1.5
32.0	46.5	67.0	M20x1.5
40.0	60.0	60.0	M20x1.5

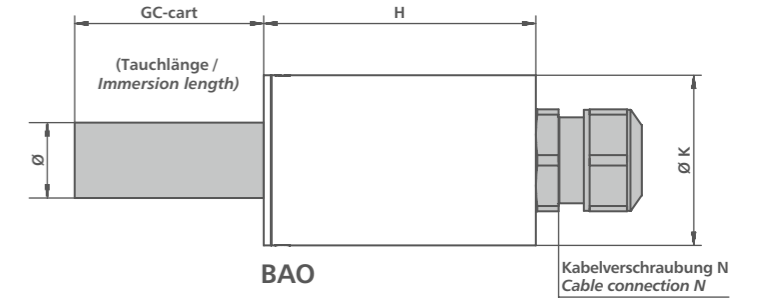

BA/BR Anschlussgehäuse  
Connection housing

Ø GC-cart	Gewinde	SW	Ø K	H	N
12.7	G 3/8"	32	31.5	65+7=72	M16x1.5
16.0	G 1/2"	32	31.5	65+8=73	M16x1.5
20.0	G 3/4"	36	36.5	65+8=73	M20x1.5
25.0	G 1"	41	36.5	65+8=73	M20x1.5
32.0	G 1 1/4"	50	46.5	65+8=73	M20x1.5
40.0	G 1 1/2"	60	60.0	60+10=70	M20x1.5

SW = wrench size

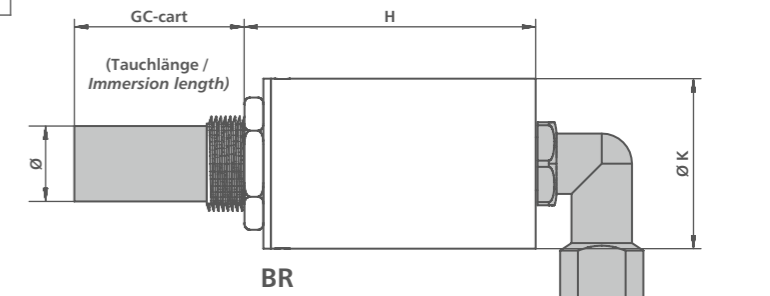
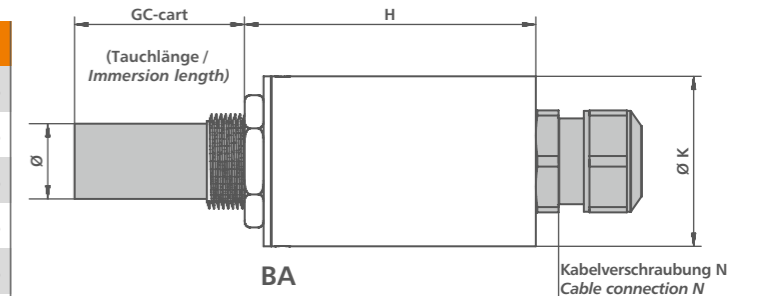

Einschraubnippel  
Screw-in nipple

N Einschraubnippel  
Screw-in nipple

Ø GC-cart	SW	N	Ø N
6.5	12.0	6.0	M 10 x 1
8.0	14.0	6.0	M 12 x 1
	3/8"	8.0	1/4"
10.0	17.0	8.0	M 14 x 1.5
12.5	19.0	8.0	M 16 x 1.5
	1/2"	8.0	3/8"
	5/8"	8.0	1/2"
16.0	24.0	8.0	M 20 x 1.5
20.0	27.0	10.0	M 26 x 1.5

SW = wrench size

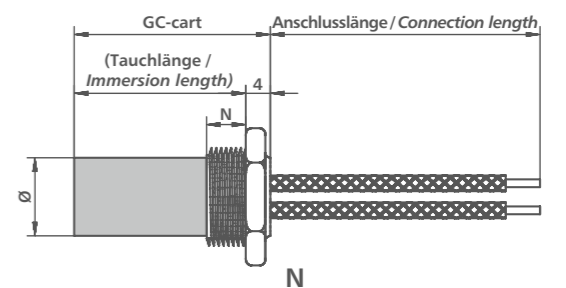

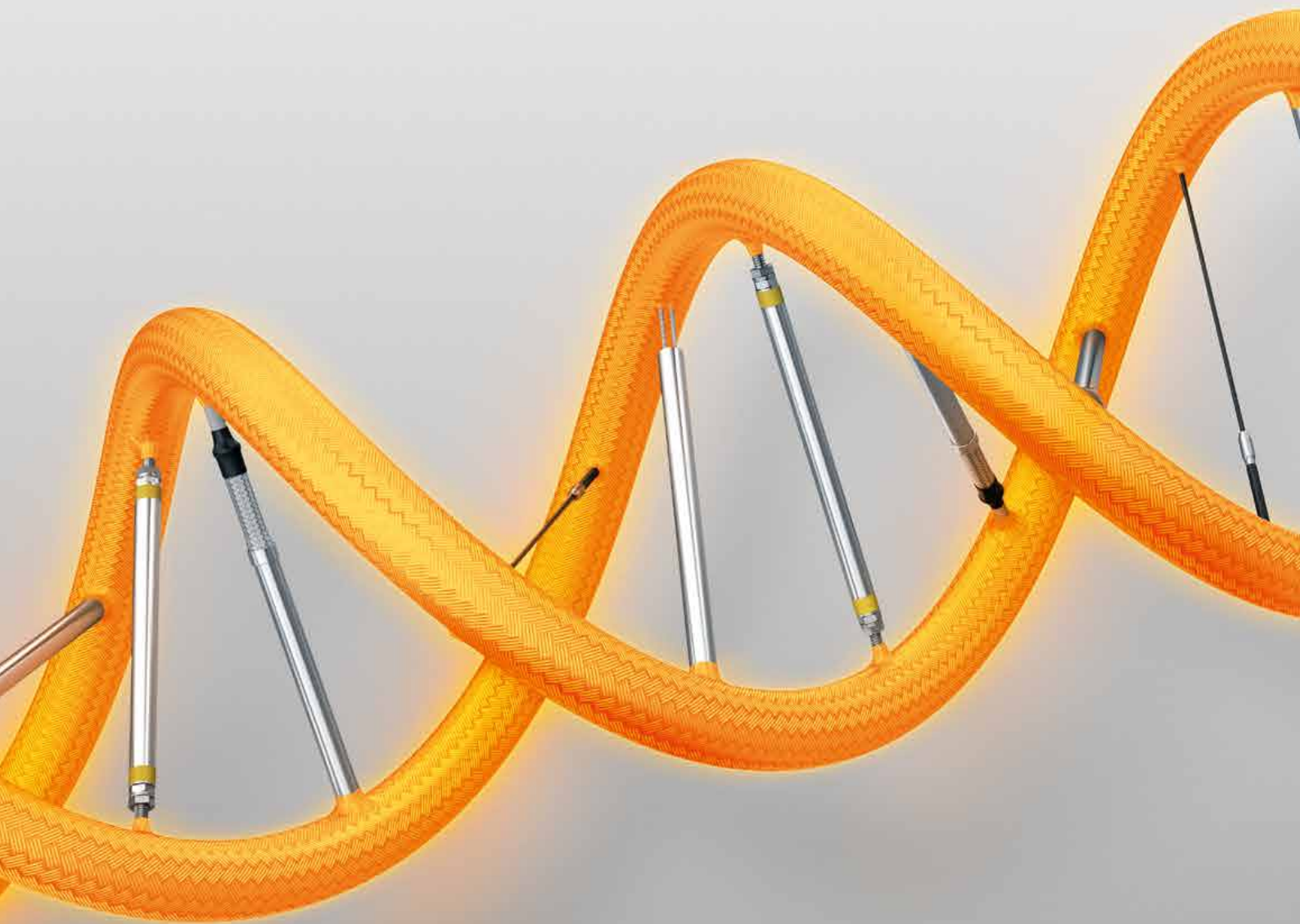

GC-heat Gebhard GmbH & Co. KG  
Industriestraße 34  
51545 Waldbröl  
Germany  
Phone +49 (0)2291 796-0  
info@gc-heat.de  
gc-heat.de

GC-heat Technology (Kunshan) Co. Ltd  
No. 329, Jujin Road, Zhangpu Township  
215321 Kunshan  
P. R. of China  
Phone +86 (0)512 8788 0081  
sales@gc-heat.cn  
gc-heat.cn

■ made  
■ in  
■ Germany

